

# ROCKY FORK STATE PARK DOCK POLICY



OHIO DEPARTMENT OF NATURAL RESOURCES  
DIVISION OF PARKS AND WATERCRAFT  
2045 MORSE ROAD, BUILDING C4  
COLUMBUS, OH 43229



Glen Cobb, Chief, ODNR Division of Parks and Watercraft

# **ROCKY FORK DOCK POLICY**

(Effective March 1, 2022)

The opportunity to have a private dock on Rocky Fork Lake is available to each landowner who shares a property boundary with Rocky Fork State Park subject to the requirements set forth in this Dock Policy.

## **CURRENT STATE CLUSTER DOCK HOLDERS AND EXISTING NON-CONFORMING STRUCTURES**

An adjacent landowner who is currently a licensed dock holder at a state owned and maintained cluster dock near their property, and who wants to continue to use that dockage in the future, must, between now and the 2024 dock season, submit a request to the Ohio Department of Natural Resources (ODNR) Division of Parks and Watercraft (Division) to assume private ownership and all future responsibility for that dock. Upon the Division's granting of such a request, the Annual Dock License Fee shall be reduced to the fee required for private moorage situated or anchored on state lands under Ohio Administrative Code 1501:46-2-08.

Non-conforming private docks that were permitted and licensed to adjacent landowners prior to the effective date of this Dock Policy may remain for the life of the structure with normal maintenance, but may not be repaired to the extent that the repair alters the original construction of the structure. An existing non-conforming private dock may be replaced by a new private dock under the policy for New Dock Construction above.

## **ANNUAL DOCK LICENSE FEE**

The Annual Dock Season runs from April 1 to October 31 of each year. All dock owners must pay the Annual Dock License Fee prior to April 1, or be subject to loss of their privilege to have a private dock.

The Annual Dock License Fee for private docks shall be the fee required for private moorage situated or anchored on state lands under Ohio Administrative Code 1501:46-2-08.

## **DOCK TRANSFER REQUESTS**

A Permit and License for a private dock issued to an adjacent landowner may be transferred when their property transfers ownership. The Permittee/Licensee must notify the Rocky Fork State Park Office in writing of the property transfer and request that the Permit and License for their dock be transferred into the name of the new adjacent landowner. Pursuant to Ohio Administrative Code 1501:46-12-03, subleasing, transfer, assignment, or unauthorized use of a private dock outside the conditions of this policy is prohibited.

### **NEW DOCK CONSTRUCTION**

**An adjacent landowner who wants to construct a new private dock near their property, or at an existing cluster dock near their property, must first apply for and obtain a Dock Construction Permit from the Division.**

**A Dock Construction Permit Application to construct, replace, modify, or substantially repair a dock at Rocky Fork Lake must also include and comply with the following:**

- **Documentation confirming that the Applicant owns property adjacent to Rocky Fork State Park and identifying the location of that adjacent property in relation to the proposed dock construction site.**
- **Measurements demonstrating that the proposed dock construction site is of sufficient existing water depth. No dredging will be permitted to prep any site.**
- **Detailed drawings of the proposed dock and bulkhead following one of the four Pre-Approved Dock Designs set forth in this Dock Policy. Fixed canopies, covers, buildings, or structures shall be strictly prohibited.**
- **A shoreline stabilization plan showing minimal shoreline construction. The dock's attachment to the shoreline should address bank erosion, but otherwise be limited to construction only as necessary for safe dock access.**
- **Dock construction standards based on Rocky Fork Lake's wave and weather factors, such as:**
  - **Heavy-duty galvanized, steel-frame floating structures with sufficiently thick, plastic coating, enclosing foam floatation, impervious to fuels, animals, and impacts.**
  - **Anchorage by slip pipe designed to sustain moving ice or to allow for removal of the dock for winter protection.**
  - **Ability of any floating dock intended to remain all year to adjust to lake level fluctuations of up to 5 feet above and 2 feet below normal pool level without damage to the dock's framework, anchorage, or flotation integrity.**
- **Dock construction materials that are new, unused, and comply with the Dock Construction Specifications set forth in this Dock Policy.**

## DOCK CONSTRUCTION SPECIFICATIONS

### STEEL TRUSS FRAMES

- 1 ½" OR 2" by 3/16" steel frames
- ½" round bar truss webbing
- Hot-dip galvanizing required
- 12" frame height
- 4' to 6' in width on walkways
- 3' to 4' in width on fingers

### FLOAT DRUMS

- Foam filled totally enclosed
- Square or rectangular design
- Min of .150 polyethylene shell

### DECKING

- Pressure treated
- Cedar plank
- Composite wood alternative

### ANCHORAGE SYSTEM

- Slip spud design
- 3" diameter spuds

### SHORE ACCESS

- Bridge or gangway attached to shore
- Must be easily unattached from dock if dock is to be winterized
- Must be attached to a bulkhead or other permanent structure with at least one hinge point

### BULKHEAD

- Legs and top plate will be made of 4"x4" angle iron ¼" thick
- Legs will be secured in concrete that is minimally 4' deep and 16" wide
- Bulkhead design can be modified for sites with a rock base during the site evaluation

**PRE-APPROVED DOCK DESIGNS**

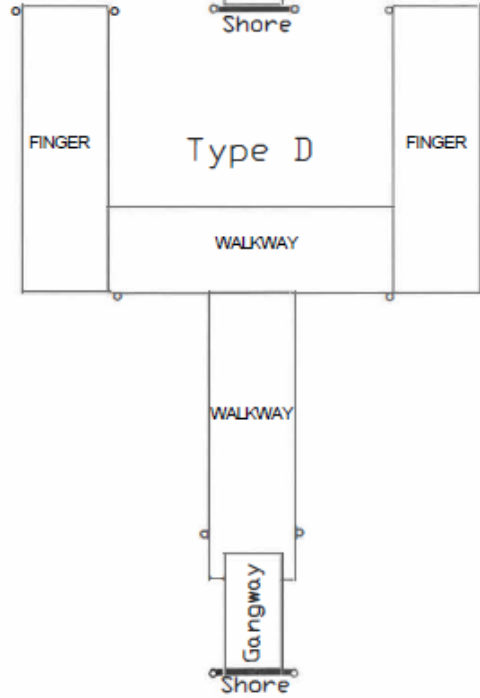
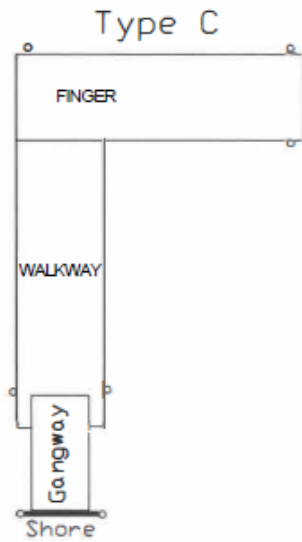
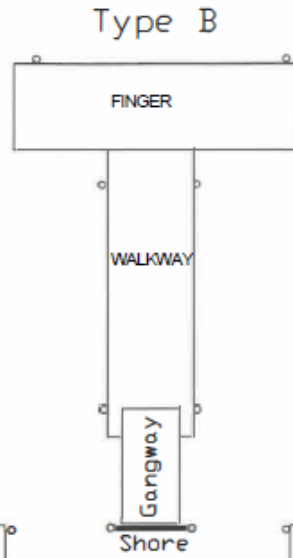
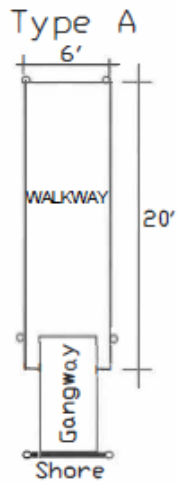

Ohio Department of Natural Resources  
Division of Parks and Watercraft

Proposed Activity: Dock Plan  
Location: Rocky Fork Park  
Date: March 2022

Scale: 1" = 10'

